

K-Reels

Dual Hose, Hydraulic Reels

Standard Features

- 3000 PSI standard swivel joint rating.
- 1. Dual port swivel joint removes easily when replacing seal.
- 2. Hose connections readily accessible.
- 3. Welded, all steel frame for maximum strength.
- Safetychange® Spring Motor makes replacement safe and easy.
- Optional Ratchet Lock.
- Pre-lubricated, sealed ball bearings.



Lift

FEET OF HOSE	STANDARD HOSE SIZES*			
	1/4" I.D.	3/8" I.D.	1/2" I.D.	3/4" I.D.
10	K18351-4-10	K21351-6-10	K18751-8-1	K241001-12-1
15	K18351-4-10	K21751-6-1	K21751-8-1	K241001-12-2
20	K21751-4-1	K21751-6-1	K21751-8-1	K281001-12-6
25	K21751-4-1	K24751-6-1	K24751-8-2	K32753-12-4
30	K24751-4-1	K24751-6-1	K28751-8-5	K32753-12-4
35	K24751-4-1	K28751-6-3	K281001-8-1	K32753-12-4
40	K28751-4-1	K28751-6-3	K321001-8-1	
45	K28751-4-1	K281001-6-1	K321001-8-1	
50	K28751-4-1	K281001-6-1	K321001-8-1	
55	K28751-4-1	K321001-6-1		
60	K321001-4-1	K321001-6-1		
65	K321001-4-1	K321001-6-1		
70	K321001-4-1			
75	K32802-4-1			
80	K32802-4-1			

Stretch

(capacities based on 6% sag)

FEET OF HOSE	STANDARD HOSE SIZES*			
	1/4" I.D.	3/8" I.D.	1/2" I.D.	3/4" I.D.
10	K18751-4-1	K18751-6-1	K18751-8-3	K241001-12-5
15	K18751-4-1	K21751-6-2	K21751-8-4	K241001-12-5
20	K21751-4-1	K21751-6-2	K21751-8-4	K28753-12-3
25	K21751-4-1	K24751-6-5	K241001-8-1	K32753-12-8
30	K24751-4-1	K24751-6-5	K281001-8-5	K32754-12-4
35	K24751-4-1	K281001-6-1	K281001-8-3	K32754-12-4
40	K281001-4-1	K281001-6-1	K32752-8-3	
45	K281001-4-1	K281001-6-1	K32752-8-3	
50	K281001-4-1	K281001-6-1	K32753-8-1	
55	K281001-4-1	K32752-6-1		
60	K321001-4-1	K32753-6-1		
65	K321001-4-1	K32753-6-1		
70	K321001-4-1			
75	K32802-4-7			
80	K32802-4-7			

Charts above based on SAE100R2 two wire braid hose. Consult factory if vinyl hose is to be used. Weights shown below for single hose without fluid.

I.D.	MAX O.D.	WEIGHT PER FOOT
0.250"	0.580"	0.330 lbs.
0.375"	0.840"	0.450 lbs.
0.500"	0.970"	0.560 lbs.
0.750"	1.250"	0.800 lbs.



GLEASON K-REEL installed on a hoist.

K-Reel

Dimensional Guide

All dimensions in inches. For millimeters, multiply inches by 25.4.

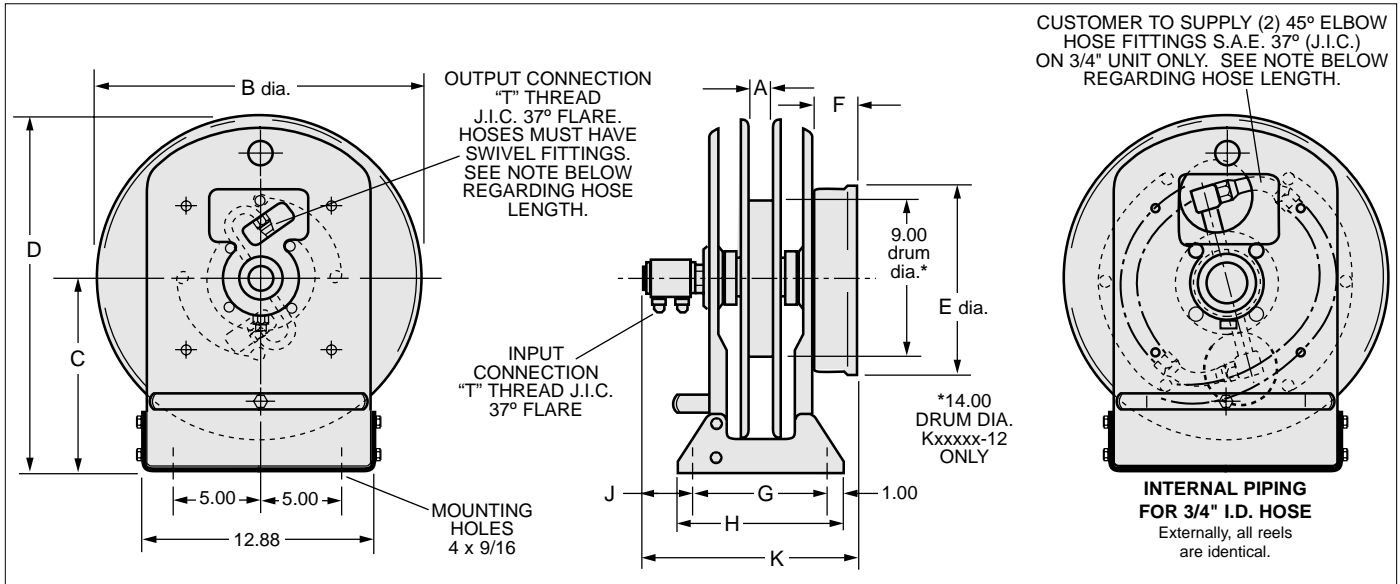

MODEL NO.	A	B	C	D	E	F	G	H	J	K	T	WEIGHT
K18351-4	1.25	18.00	10.75	19.75	10.59	2.50	7.50	9.50	2.88	12.12	.56-18	115 lbs.
K18751-4	1.25	18.00	10.75	19.75	10.59	3.00	7.50	9.50	2.88	12.62	.56-18	120 lbs.
K21751-4	1.25	21.00	12.50	23.00	10.59	3.00	7.50	9.50	2.88	12.62	.56-18	130 lbs.
K24751-4	1.25	24.00	14.00	26.00	10.59	3.00	7.50	9.50	2.88	12.62	.56-18	140 lbs.
K28751-4	1.25	28.00	16.00	30.00	10.59	3.00	7.50	9.50	2.88	12.62	.56-18	150 lbs.
K281001-4	1.25	28.00	16.00	30.00	14.34	4.00	7.50	9.50	2.88	13.62	.56-18	160 lbs.
K32802-4	1.25	32.00	18.00	34.00	14.34	5.38	7.50	9.50	2.88	15.00	.56-18	235 lbs.
K321001-4	1.25	32.00	18.00	34.00	14.34	4.00	7.50	9.50	2.88	13.62	.56-18	180 lbs.
K18751-6	1.75	18.00	10.75	19.75	10.59	3.00	8.00	10.00	2.88	13.12	.75-16	120 lbs.
K21351-6	1.75	21.00	12.50	23.00	10.59	2.50	8.00	10.00	2.88	12.62	.75-16	115 lbs.
K21751-6	1.75	21.00	12.50	23.00	10.59	3.00	8.00	10.00	2.88	13.12	.75-16	130 lbs.
K24751-6	1.75	24.00	14.00	26.00	10.59	3.00	8.00	10.00	2.88	13.12	.75-16	140 lbs.
K28751-6	1.75	28.00	16.00	30.00	10.59	3.00	8.00	10.00	2.88	13.12	.75-16	155 lbs.
K281001-6	1.75	28.00	16.00	30.00	14.34	4.00	8.00	10.00	2.88	14.12	.75-16	165 lbs.
K32752-6	1.75	32.00	18.00	34.00	10.59	5.38	8.00	10.00	2.88	15.50	.75-16	225 lbs.
K32753-6	1.75	32.00	18.00	34.00	10.59	7.75	8.00	10.00	2.88	17.88	.75-16	280 lbs.
K321001-6	1.75	32.00	18.00	34.00	14.34	4.00	8.00	10.00	2.88	14.12	.75-16	180 lbs.
K18751-8	2.12	18.00	10.75	19.75	10.59	3.00	8.38	10.38	2.88	13.50	.88-14	120 lbs.
K21751-8	2.12	21.00	12.50	23.00	10.59	3.00	8.38	10.38	2.88	13.50	.88-14	130 lbs.
K24751-8	2.12	24.00	14.00	26.00	10.59	3.00	8.38	10.38	2.88	13.50	.88-14	140 lbs.
K241001-8	2.12	24.00	14.00	26.00	14.59	4.00	8.38	10.38	2.88	14.50	.88-14	150 lbs.
K28751-8	2.12	28.00	16.00	30.00	10.59	3.00	8.38	10.38	2.88	13.50	.88-14	155 lbs.
K281001-8	2.12	28.00	16.00	30.00	14.34	4.00	8.38	10.38	2.88	14.50	.88-14	165 lbs.
K32752-8	2.12	32.00	18.00	34.00	10.59	5.38	8.38	10.38	2.88	15.88	.88-14	225 lbs.
K32753-8	2.12	32.00	18.00	34.00	10.59	7.75	8.38	10.38	2.88	18.25	.88-14	280 lbs.
K321001-8	2.12	32.00	18.00	34.00	14.34	4.00	8.38	10.38	2.88	14.50	.88-14	180 lbs.
K241001-12	2.75	24.00	14.00	26.00	14.34	4.00	9.00	11.00	2.88	16.77	1.06-12	160 lbs.
K28753-12	2.75	28.00	16.00	30.00	10.59	7.75	9.00	11.00	2.88	20.56	1.06-12	275 lbs.
K281001-12	2.75	28.00	16.00	30.00	14.34	4.00	9.00	11.00	2.88	16.77	1.06-12	175 lbs.
K32753-12	2.75	32.00	18.00	34.00	10.59	7.75	9.00	11.00	2.88	20.56	1.06-12	290 lbs.
K32754-12	2.75	32.00	18.00	34.00	10.59	10.12	9.00	11.00	2.88	22.88	1.06-12	350 lbs.

NOTE REGARDING HOSE LENGTH: Because hoses attach to reel on opposite sides of spool core (see drawings above), one hose must be longer than the other per following table.

Optional Ratchet Lock
All Models: Part No. 014209

1/4" i.d.....12"
3/8" i.d.....16"
1/2" i.d.....16"
3/4" i.d.....24"