

DECREASE TENSION if load cannot easily be pulled down to desired height.

1. If reel is so equipped, turn ratchet lock to "OFF" (knob is located on side of reel).
2. Place wrench on flats of shaft.
3. Hold shaft **firmly** with wrench. Depress spring on opposite side of reel.
4. Allow shaft to turn **SLOWLY** in **clockwise** direction until desired tension is achieved. If shaft will not turn in clockwise direction UNASSISTED, reel is at minimum tension and further tension reduction should not be attempted.

DANGER

DO NOT allow spring to unwind in an uncontrolled manner. Doing so can result in damage to reel or personal injury.

RATCHET LOCK USE

If reel is equipped with ratchet lock ("L" models), engage by pulling cable out to desired position and letting it retract **SLOWLY** until lock engages. To release lock, quickly pull cable out a short distance and allow it to begin to retract—it operates like a window shade. Ratchet lock may be disengaged by turning knob on side of reel.

SERVICE

REGULAR MAINTENANCE

1. Reel is factory lubricated for life. No additional lubrication is required.
2. Periodically check cable for wear. **If wear is detected, cable should be replaced immediately.** If cable replacement is required, order cable Assembly, Kit No. 5, which contains cable and related parts, hardware and instructions. See Parts List (inside) for details.

SPRING REPLACEMENT

Spring motors are self-contained for safe and easy handling. If spring motor replacement is required, it should be replaced as a unit by ordering Spring Motor Assembly, Kit No. 1, which contains the spring motor, spool, shaft & bushings in a sealed canister. See Parts List (inside) for details.

DANGER

DO NOT attempt to remove spring motor from its canister. Doing so can result in damage to reel or personal injury.

RATCHET LOCK REPLACEMENT

For your convenience, the ratchet lock assembly has been included in two separate replacement kits. Order either the Hardware Package, Kit No. 7, or the RH Housing Assembly, Kit No. 2. See Parts List (inside) for details.



Workplace Solutions

Gleason Reel Corp.

600 South Clark St. • P.O. Box 26
Mayville, WI 53050
Phone: 920-387-4120
Fax: 920-387-4189
www.hubbell-gleason.com

INSTALLATION & MAINTENANCE INSTRUCTIONS

Series "BG" Tool Balancers

INSTALLATION

NOTE: To minimize wear on cable and cable guide, reel should be mounted directly over work area and, preferably, on a rolling trolley so that cable is pulled out as straight as possible during use. **Keep a minimum of 6 inches between ball stop and swedge.**

MOUNT REEL

1. Use clevis to hang reel in desired location. Be sure cotter pin is installed on clevis pin.
2. Attach optional safety chain to secondary hanger bracket or other overhead support. Do not use the same attachment point as used for the clevis. See Figure 1.

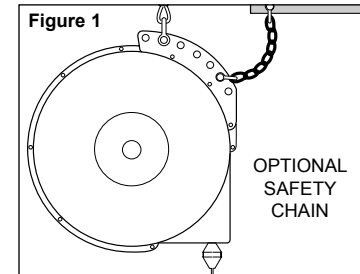

CAUTION

To prevent reel fall should primary clevis mount fail, it is recommended that a safety chain be used from reel to a secure secondary support. Failure to use safety chain could result in personal injury.

ATTACHING LOAD

For most effective use of reel, tool (Figure 2) should be positioned at **top** of working range with **no cable pulled off reel**. Use overhang cables to achieve proper distance *from reel to tool*. Cable on reel should be used only to move tool within working range.

To attach load (all components hung on reel), raise load to safety clip and attach. **DO NOT pull cable down to load.**

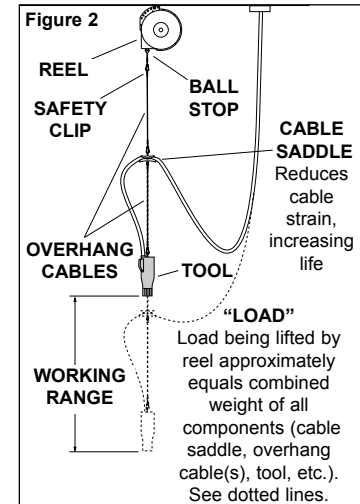

CAUTION

Always raise load to safety clip on cable reel. **DO NOT** pull reel cable down to load. Doing so can result in damage to reel or personal injury.

TENSION ADJUSTMENT

INCREASE TENSION if reel will not completely rewind cable with load attached until cable stop reaches guide.

1. Allow cable to retract as far as possible.
2. Place wrench on flats of shaft. Turn shaft **counter-clockwise** until cable stop reaches guide.

BALANCE REEL ILLUSTRATED PARTS LIST

Replacement parts available as kits only.

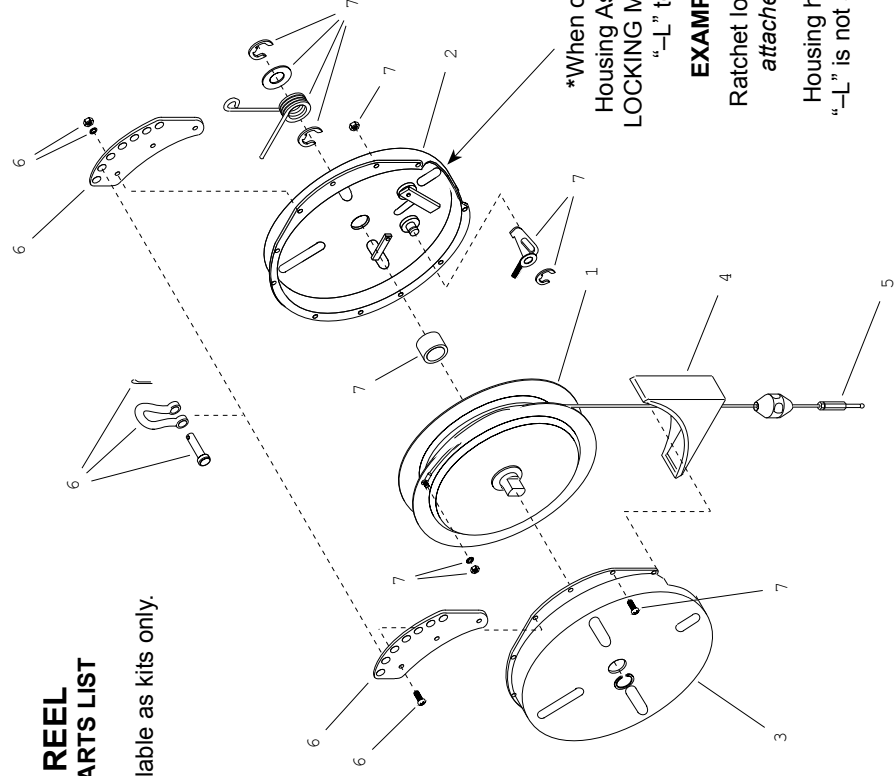

NOTE:

*When ordering Right Hand Housing Assembly (Kit no. 2) for **LOCKING MODELS**, you must add “-L” to the kit number.

EXAMPLE: BG10-K02-L

Ratchet lock assembly will ship *attached* to housing half.

Housing half only is supplied if “-L” is not added to part number.

BALANCE REEL

REPLACEMENT PARTS KITS

REF. NO.	KIT NUMBER		KIT DESCRIPTION
	BG10	BG12	
1	BG10-K01	BG12-K01	SPRING MOTOR ASSY: Spring Motor, Spool, Shaft & Bushings in sealed canister.
2	BG10-K02*	BG12-K02*	RH HOUSING ASS'Y: RH Housing Half, Ratchet Lock Ass'y (Ratchet lock ass'y on “-L” models only. Add -L to kit number).*
3	BG10-K03	BG12-K03	LH HOUSING ASS'Y: LH Housing Half, Nameplate.
4	BG10-K04	BG12-K04	CABLE GUIDE
5	BG10-K05	BG12-K05	CABLE ASS'Y: Cable, Safety Clip, Lockwasher-M4, Hex Nut-M4.
6	BG10-K06	BG12-K06	HANGING BRACKET ASS'Y: Hanging Bracket, Clevis, Clevis Pin, Cotter Pin, Slotted Machine Screw M14 x 14mm (3), Lockwasher-M4 (3), Hex Nut-M4 (3)
7	BG10-K07	BG12-K07	HARDWARE PACKAGE: Spacer, Torsion Spring, Slotted Machine Screw M4 x 14mm (3), Slotted Machine Screw M4 x 8mm (6), Lockwasher-M4 (10), Hex Nut-M4 (10), Retaining Ring (3), Shim, Extension Spring, and Ratchet Lock Assembly.

* For “-L” models (with ratchet lock), add -L to kit no. 2.

EXAMPLE: BG10-K02-L

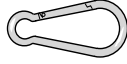

#STC-01
SAFETY CLIP

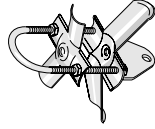

ADJUSTABLE
CABLE SADDLE

CABLE DIAMETER in.	MODEL NO.
0.3 - 0.59 (7 - 14)	CS-F1
0.6 - 0.94 (15 - 23)	CS-F2
0.95 - 1.25 (24 - 31)	CS-F3

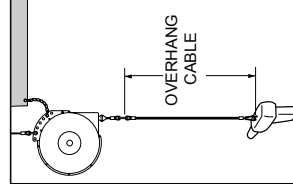

OVERHANG CABLE

LENGTH ft.	MODEL NO.
3 (0.9)	OC-03
5 (1.5)	OC-05
10 (3.0)	OC-10
15 (4.6)	OC-15

TORQUE REEL ACCESSORIES